

Model / Model		A145-315Nm 1000-1,00
Yük-Yolcu / Load-Person		1000 Kg (13 Person)
Hız / Speed		1,0 m/s
Aski / Roping		2 / 1
Kasnak-Hatve / Sheave-Pitch		ø210 x 8 x ø6,5 / 12
V Kanal Açısı / V Groove Angle		45°
Enkoder / Encoder		Endat / Sincos / Biss-C
Fren / Brake Magnet		207 V DC / (220 V AC Rectifier)
Duty Cycle / Görev Faktörü		53 40%
Machine Weight / Makine Ağırlığı		195Kg
Maks. Statik Yük / Max. Static Load		4500Kg (2/1)
Tork / Torque		315 NM
Bağlantı / Connect		(Y) Star
Devir / Motor RPM		180 RPM
Frekans / Frequency		48 Hz
Kutup Sayısı / Number of Poles		32 Poles
Motor Gücü / Motor Power		5,94 Kw
Akım / Current		13,6 A
Voltaj / Terminal Voltage		355 V AC
Cosφ / Cos φ		0,85

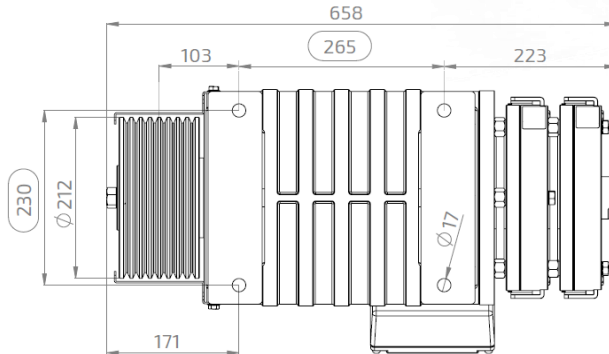
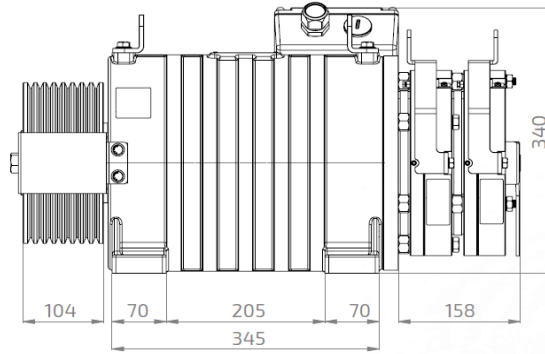
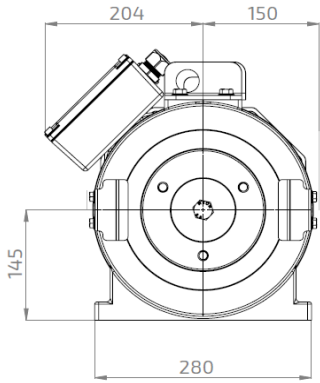

Astes Asansör ölçüler ve veriler üzerinde değişiklik yapma hakkına sahiptir.

The dimensions and data are subject to change without notice.