

Model / Model		A145-250Nm 0800-1,60
Yük-Yolcu / Load-Person		800 Kg (10 Person)
Hız / Speed		1,6 m/s
Aski / Roping		2 / 1
Kasnak-Hatve / Sheave-Pitch		ø210 x 7 x ø6,5 / 12
V Kanal Açısı / V Groove Angle		45°
Enkoder / Encoder		Endat / Sincos / Biss-C
Fren / Brake Magnet		207 V DC
Duty Cycle / Görev Faktörü		53 40%
Machine Weight / Makine Ağırlığı		180Kg
Maks. Statik Yük / Max. Static Load		4500Kg (2/1)
Tork / Torque		250 NM
Bağlantı / Connect		(Δ) Delta
Devir / Motor RPM		290 RPM
Frekans / Frequency		77,33 Hz
Kutup Sayısı / Number of Poles		32 Poles
Motor Gücü / Motor Power		7,59 Kw
Akım / Current		18,7 A
Voltaj / Terminal Voltage		323 V AC
Cosφ / Cos φ		0,83

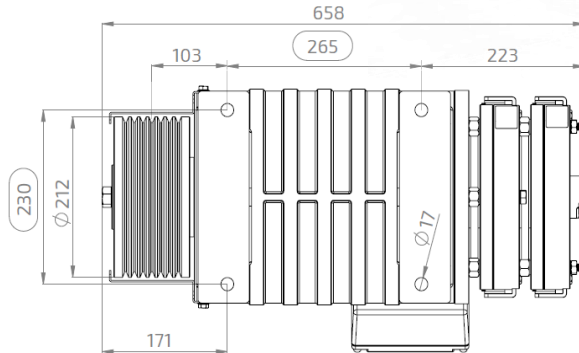
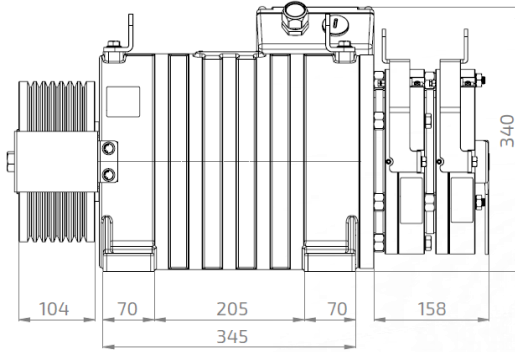
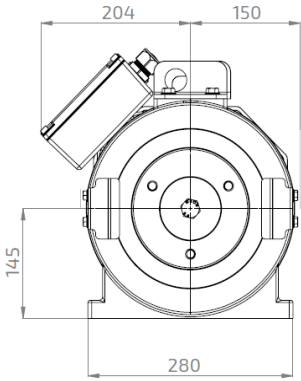

Astes Asansör ölçüler ve veriler üzerinde değişiklik yapma hakkına sahiptir.

The dimensions and data are subject to change without notice.