

Model / Model

A145-250Nm 0800-1,00

Yük-Yolcu	/ Load-Person	800 Kg (10 Person)
Hız	/ Speed	1,0 m/s
Aski	/ Roping	2 / 1
Kasnak-Hatve	/ Sheave-Pitch	ø210 x 7 x ø6,5 / 12
V Kanal Açısı	/ V Groove Angle	45°
Enkoder	/ Encoder	Endat / Sincos / Biss-C
Fren	/ Brake Magnet	200 V DC
Duty Cycle	/ Görev Faktörü	S3 40%
Machine Weight	/ Makine Ağırlığı	180Kg
Maks. Statik Yük	/ Max. Static Load	4500Kg (2/1)
Tork	/ Torque	250 Nm
Bağlantı	/ Connect	(Y) Star
Devir	/ Motor RPM	180 RPM
Frekans	/ Frequency	48 Hz
Kutup Sayısı	/ Number of Poles	32 Poles
Motor Gücü	/ Motor Power	4,71 kW
Akım	/ Current	10,8 A
Voltaj	/ Terminal Voltage	357 V AC
Cosφ	/ Cos φ	0,85

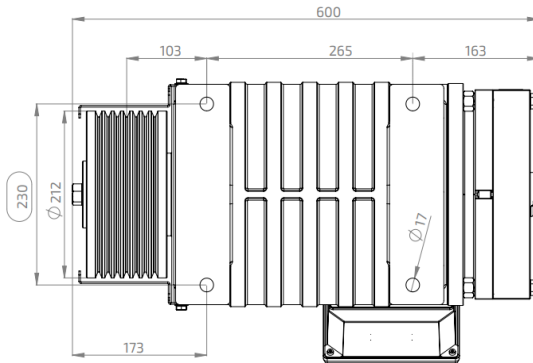
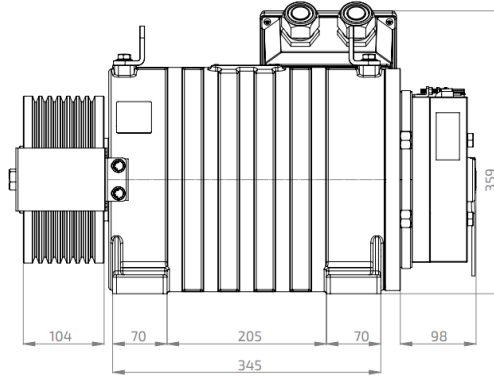
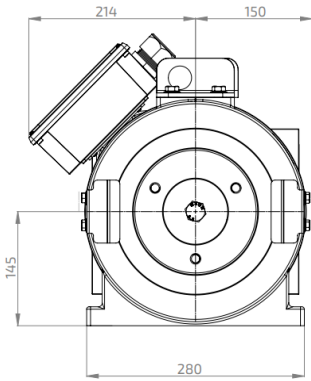

Astes Asansör ölçüler ve veriler üzerinde değişiklik yapma hakkına sahiptir.

The dimensions and data are subject to change without notice.

Factory: Fevzipasa Mah. Gülbağlar Sok. No:9 Değirmenköy - Silivri - İstanbul - TÜRKİYE

T:+90 212 723 53 73 (pbx) F: +90 212 723 53 76

Web: www.astes.com.tr E-Mail: astes@astes.com.tr