

Model / Model	:	A4-80 KA 0,40
Kontrol / Control	:	One Speed
Aski / Roping	:	1 / 1
Yük / Load	:	150 Kg
Hız / Speed	:	0,4 m/s
Motor / Motor	:	380 VAC / 50Hz
Motor Gücü / Motor Power	:	0,75 Kw
Devir / Motor RPM	:	950 RPM
Akım / Motor Current	:	2,6 A
Aktarma Oranı / Ratio	:	30 / 1
Kasnak-Hatve / Sheave-Pitch	:	ø240 x 2 x ø6 / 12
Kanal Açısı / Groove Angle	:	35°
Fren / Brake Magnet	:	220 VAC
Yağ-Kapasite / Gear Oil-Capacity	:	Mobil Gear 600 XP320 / 1Lt.
Maks. Statik yük / Max. Static Load	:	500Kg

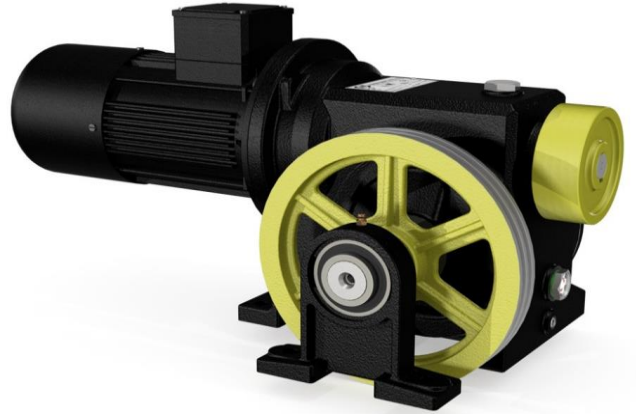
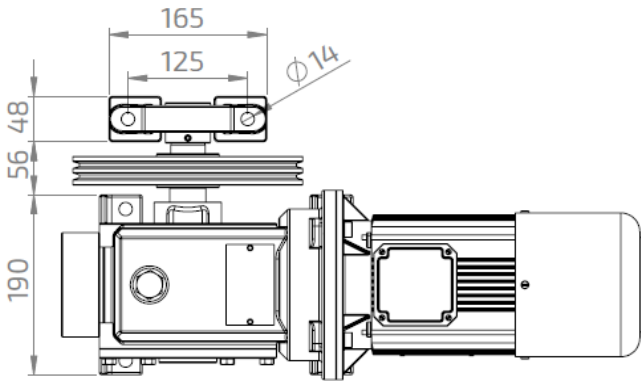
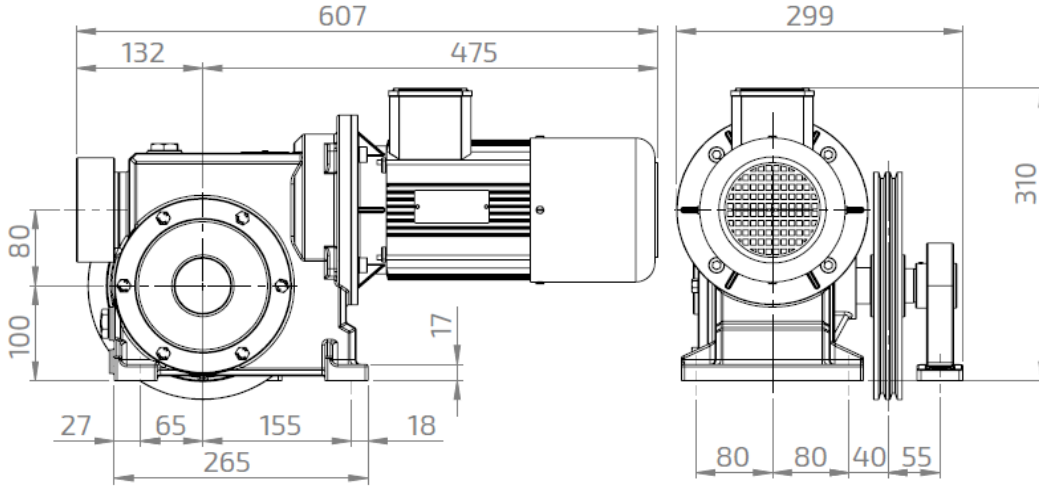

Astes Asansör ölçüler ve veriler üzerinde değişiklik yapma hakkına sahiptir.

The dimensions and data are subject to change without notice.