

<b>Model / Model</b>	:	<b>A4-150 VVVF 1600-1,0</b>
<b>Kontrol / Control</b>	:	VVVF/ Encoder
<b>Aski / Roping</b>	:	2 / 1
<b>Yük / Load</b>	:	1600 Kg (2/1)
<b>Hız / Speed</b>	:	Max. 1,0 m/s (2/1)
<b>Motor / Motor</b>	:	380 VAC / 50Hz
<b>Motor Gücü / Motor Power</b>	:	12,5 Kw
<b>Devir / Motor RPM</b>	:	1500 RPM
<b>Akım / Motor Current</b>	:	27 A
<b>Aktarma Oranı / Ratio</b>	:	39 / 2
<b>Kasnak-Hatve / Sheave-Pitch</b>	:	ø480 x 5 x ø10 / 16
<b>Kanal Açısı / Groove Angle</b>	:	40°
<b>Fren / Brake Magnet</b>	:	195 VDC
<b>Yağ-Kapasite / Gear Oil-Capacity</b>	:	Mobil Gear 600 XP320 / 5Lt.
<b>Maks. Statik yük / Max. Static Load</b>	:	8000 Kg (2/1)

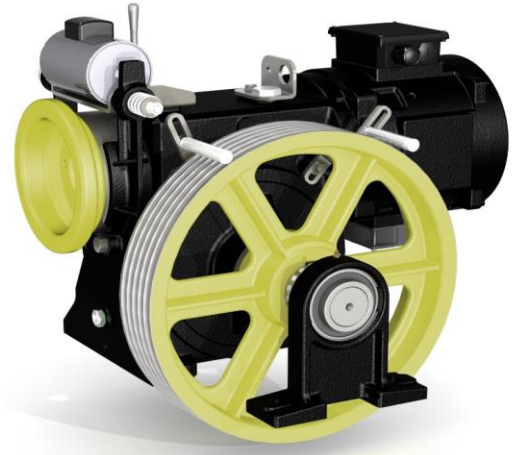
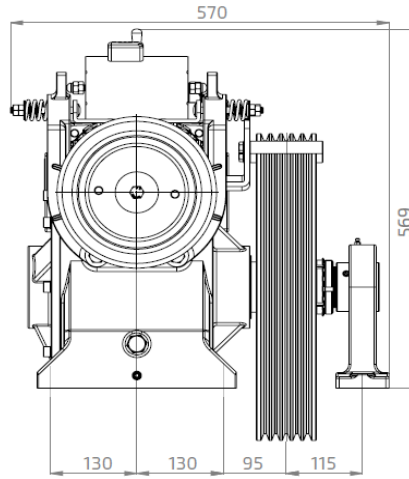
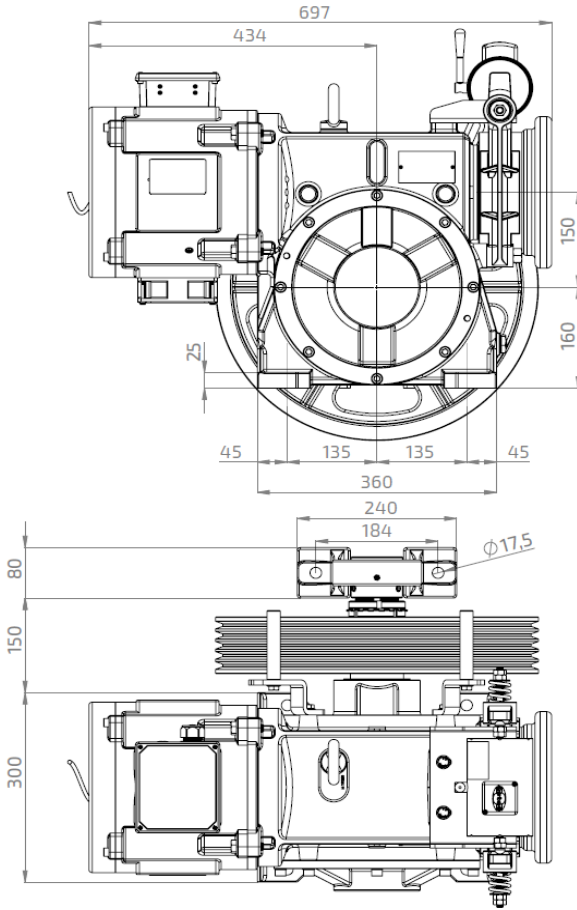

Astes Asansör ölçüler ve veriler üzerinde değişiklik yapma hakkına sahiptir.

The dimensions and data are subject to change without notice.