

**Model / Model** : **A4-135 VVF 1250-1,0**

<b>Kontrol / Control</b>	:	VVF/ Encoder
<b>Askı / Roping</b>	:	2 / 1
<b>Yük / Load</b>	:	1250 Kg (2/1)
<b>Hız / Speed</b>	:	Max. 1,0 m/s (2/1)
<b>Motor / Motor</b>	:	380 VAC / 50Hz
<b>Motor Gücü / Motor Power</b>	:	10 Kw
<b>Devir / Motor RPM</b>	:	1500 RPM
<b>Akım / Motor Current</b>	:	23 A
<b>Aktarma Oranı / Ratio</b>	:	41 / 2
<b>Kasnak-Hatve / Sheave-Pitch</b>	:	ø480 x 5 x ø10 / 16
<b>Kanal Açısı / Groove Angle</b>	:	40°
<b>Fren / Brake Magnet</b>	:	195 VDC
<b>Yağ-Kapasite / Gear Oil-Capacity</b>	:	Mobil Gear 600 XP320 / 3Lt.
<b>Maks. Statik yük / Max. Static Load</b>	:	7000 Kg (2/1)

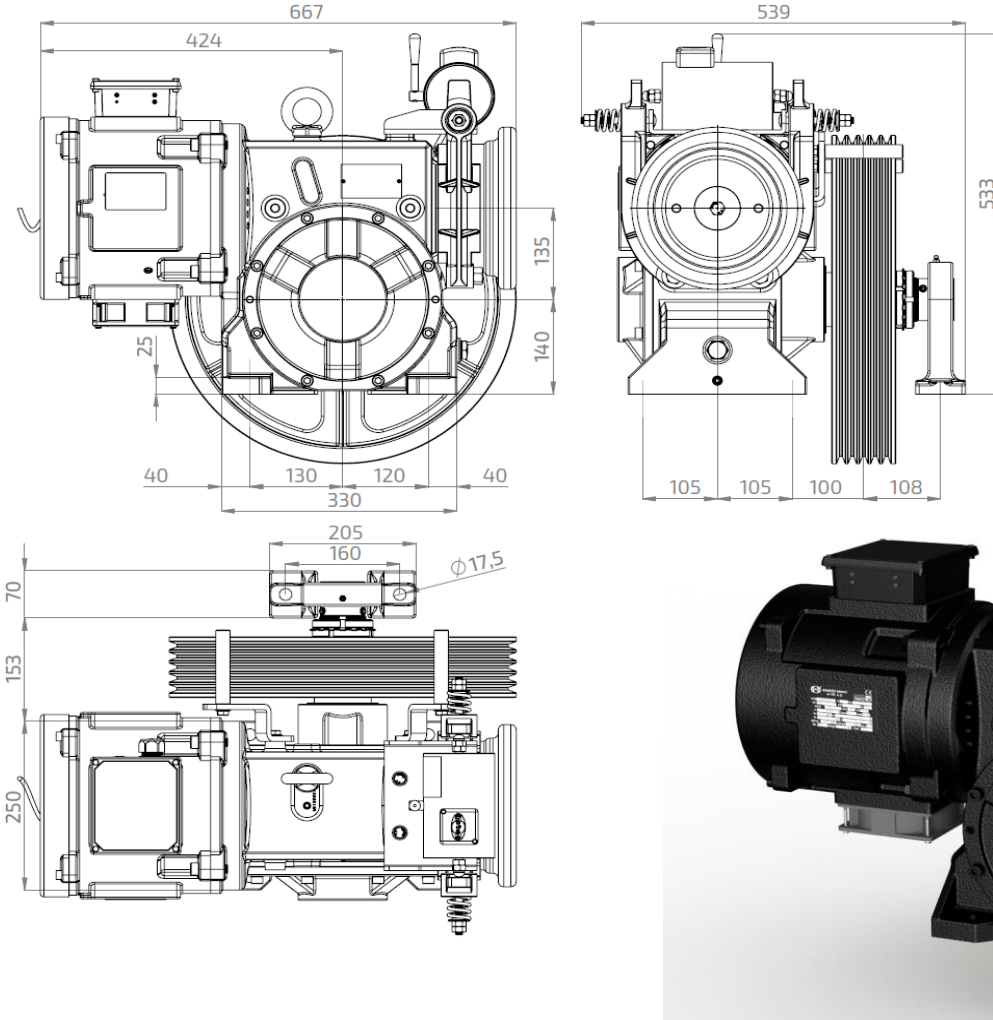

Astes Asansör ölçüler ve veriler üzerinde değişiklik yapma hakkına sahiptir.

The dimensions and data are subject to change without notice.