

Model / Model	:	A4-135 AC2 630-1,0
Kontrol / Control	:	AC2 Two Speed
Aski / Roping	:	1 / 1
Yük / Load	:	630 Kg
Hız / Speed	:	1/0,25 m/s
Motor / Motor	:	380 VAC / 50Hz
Motor Gücü / Motor Power	:	7,5 / 1,87 Kw
Devir / Motor RPM	:	1500 / 375 RPM
Akım / Motor Current	:	16 / 10 A
Aktarma Oranı / Ratio	:	40 / 1
Kasnak-Hatve / Sheave-Pitch	:	ø480 x 5 x ø10 / 16
Kanal Açısı / Groove Angle	:	40°
Fren / Brake Magnet	:	195 VDC
Yağ-Kapasite / Gear Oil-Capacity	:	Mobil Gear 600 XP320 / 3Lt.
Maks. Statik yük / Max. Static Load	:	3500Kg

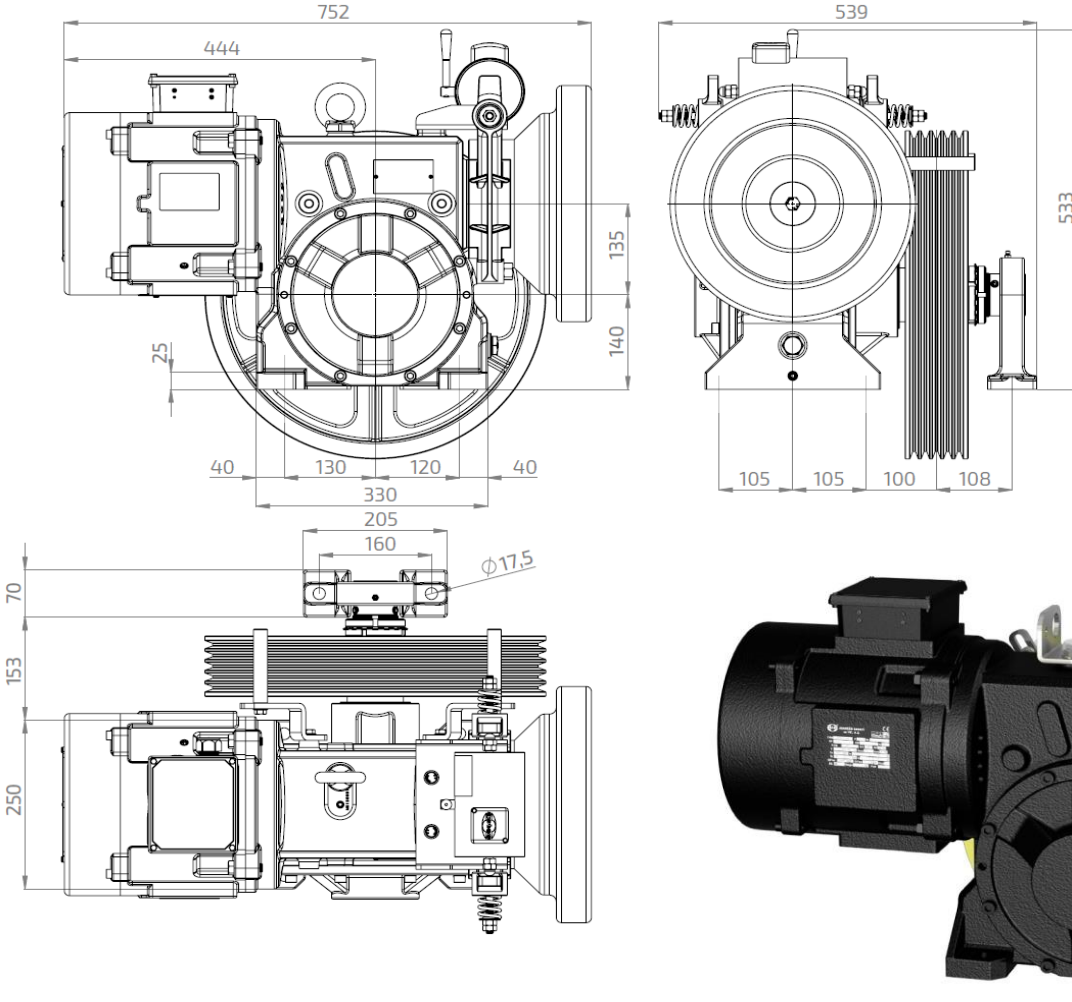

Astes Asansör ölçüler ve veriler üzerinde değişiklik yapma hakkına sahiptir.

The dimensions and data are subject to change without notice.