

Model / Model : **A175-525Nm 1600-1,00**

| | | | |
|--|---|---------------------|-------|
| Kontrol / Control | : | Senkron / Encoder | |
| Aski / Roping | : | 2 / 1 | |
| Yük / Load | : | 1600 Kg | (2/1) |
| Hız / Speed | : | Max. 1,0 m/s | (2/1) |
| Kasnak-Hatve / Sheave-Pitch | : | ø210 x 8 x ø8 / 14 | |
| Kanal Açısı / Groove Angle | : | 45° | |
| Bağlantı / Connect | : | (Y) Star | |
| Tork / Torque | : | 525 Nm | |
| Motor Gücü / Motor Power | : | 9,90 Kw | |
| Devir / Motor RPM | : | Max. 180 RPM | |
| Frekans / Frequency | : | 66 Hz | |
| Kutup Sayısı / Number of Poles | : | 44 Poles | |
| Cosφ / Cos φ | : | 0,90 | |
| Akım / Current | : | 21 A | |
| Voltaj / Terminal Voltage | : | 351 V AC | |
| Fren / Brake Magnet | : | 207 V DC | |
| Maks. Statik yük / Max. Static Load | : | 7000Kg | (2/1) |

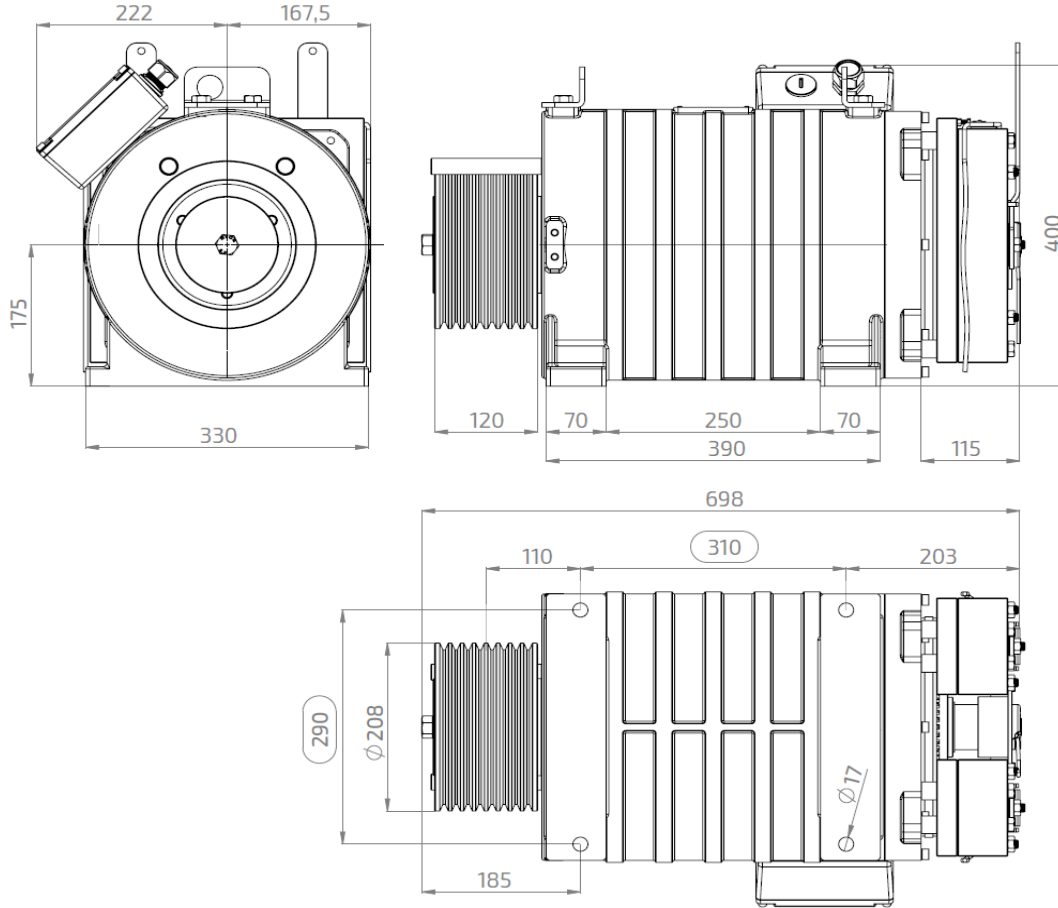

Astes Asansör ölçüler ve veriler üzerinde değişiklik yapma hakkına sahiptir.

The dimensions and data are subject to change without notice.